

# NO-NONSENSE

**THIS TRUCK HOPPER DOESN'T  
MESS AROUND**

THERE'S  
WORK  
TO DO.



Box 8 • 2002 Kingbird Ave. • George, IA 51237 USA  
1-888-SUDENGA (783-3642) • 1-712-475-3301  
Fax: 1-712-475-3320 • sales@sudenga.com • www.sudenga.com



Short elevation and high capacities situation? Try the Ox Truck Hopper on for size. 6' or 8' incline tubes and capacities up to 6,500 BPH. It's versatile and it's well-balanced. Available in electric or hydraulic drive. It gets in, and then it gets out. No funny business.



# TRUCK HOPPER

## STANDARD FEATURES

### Hopper

- 14 ga. construction; splash guard on intake; access to CV-joint on hopper to incline fighting connection; flexible rubber belting; rubber end wheels; safety screen over hopper fighting; 4" flex skirt (keeps hopper full of grain, minimizes spillage, and improves low clearance access)
- 7-1/4" fighting (8" incline tube), 9-1/4" fighting (10" incline tube), and 11-1/4" fighting (12" incline tube).
- 10" hoppers have reduced pitch fighting.

### Incline Auger

- 14 ga. (8" diameter) or 12 ga. (10"/12" diameter) cold drawn welded tube; 7-1/4" fighting (8" incline tube), 9-1/4" fighting (10" incline tube), 11-1/4" fighting (12" incline tube).

### Fighting

- 3/16" on 1-1/2" pipe (7-1/4" fighting), 3/16" on 2-1/2" pipe (9-1/4" fighting), 1/4" on 2-7/8" pipe (11-1/4" fighting).
- Hopper flightings are 5/16" thick on all sizes.

### POWER REQUIREMENTS

Tube Diameter	8"	10"	12"
Electric Drive*	2 HP	3 HP	5 HP
Hydraulic Drive	"H" Series		

\*For Dry Grain Applications

### OPTIONAL FEATURES

- Transport: Tube mounted undercarriage that makes moving the hopper easy. Includes two 4 x 8 tubeless tires.
- Swivel Wheel Adaptor: Allows fixed-end wheels to swivel 360°. Makes positioning the hopper easy.
- Leg Adaptor: For attaching hopper discharge to the elevator leg intake. Eliminates moisture problems associated with dump pits.
- Custom lengths available on request.



OPTIONAL SWIVEL END WHEELS



WIDE HOPPER WITH FLEX SKIRT

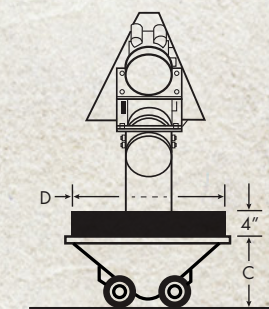
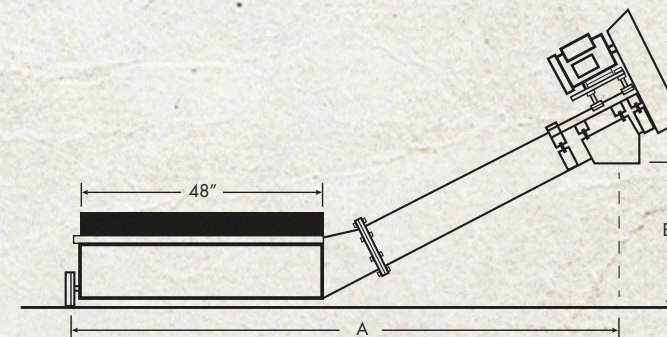

## HOPPER DIMENSIONS

	8" x 6'	8" x 8'	10" x 6'	10" x 8'	12" x 8'
A	8'- 11-3/4"	10' 9"	8' - 11"	10' - 8-1/2"	10'- 8-1/4"
B <sup>1</sup>	25-1/2"	36-1/4"	25"	36"	34-3/4"
C <sup>1</sup>	10-3/4"	10-3/4"	13"	13"	13"
D <sup>2</sup>	28'-1/2"	28-1/2"	32-1/4"	32-1/4"	32-1/4"

<sup>1</sup> "B" and "C" dimensions are for standard 6" end wheels in top-mount holes.

Add 1" for 6" wheels in lower mount holes or optional swivel end wheels.

<sup>2</sup> "D" dimension is for hopper width inside of hopper skirt.

## CAPACITIES\*

8" Incline Tube	2500 BPH
10" Incline Tube	4500 BPH
12" Incline Tube	6500 BPH

\*In dry grain, choose next size auger in wet grain