

BULK BAG SYSTEM



**STRONG, STABLE
CONSTRUCTION
WITH SECURE
BAG PLACEMENT**

**HOPPER OPTION SERVES AS BUFFER
DURING BAG REPLACEMENT**



**COST EFFECTIVE MANAGEMENT
OF MINOR/MICRO INGREDIENTS**

BULK BAG SYSTEM

SPECIFICATIONS

	A (min)	A (max)	B	C	D	E (min)	E (max)	F	G	H	I (min)	I (max)
Inches	127¼"	175¼"	30"	12"	60"	71¼"	119¼"	63"	66"	16"	52¾"	100¾"
Centimeters	324	446	76.2	2.54	152.4	181	303	160	168	40.6	134	256

For this and all of your feed production requirements, contact your nearest representative or contact us directly.

REMOVABLE TOP

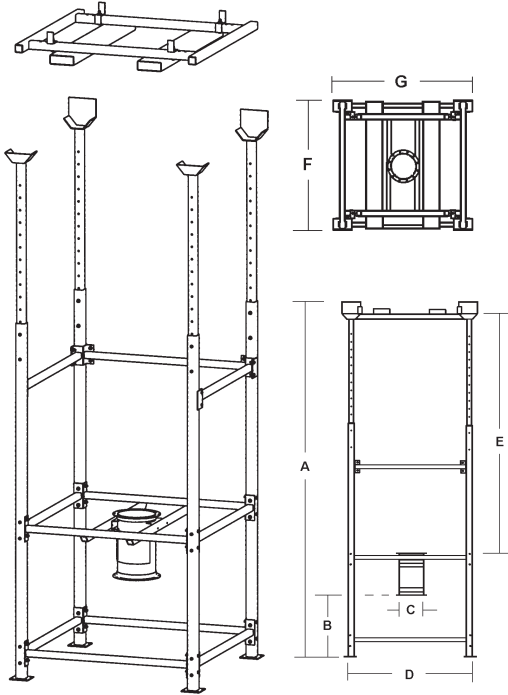

BULK BAG MINOR SCALE SYSTEM:

- Provides accurate weighing of minor ingredients into your batching system.
- The system offers speed by conveying material with high speed conveyors from the hopper directly below the bulk bag stand into a highly accurate scale system with funnel hopper.
- The bulk bags minor scale utilizes bulk bag frames for speed and safety in replacing empty bulk bags.

OPTIONAL HOPPER

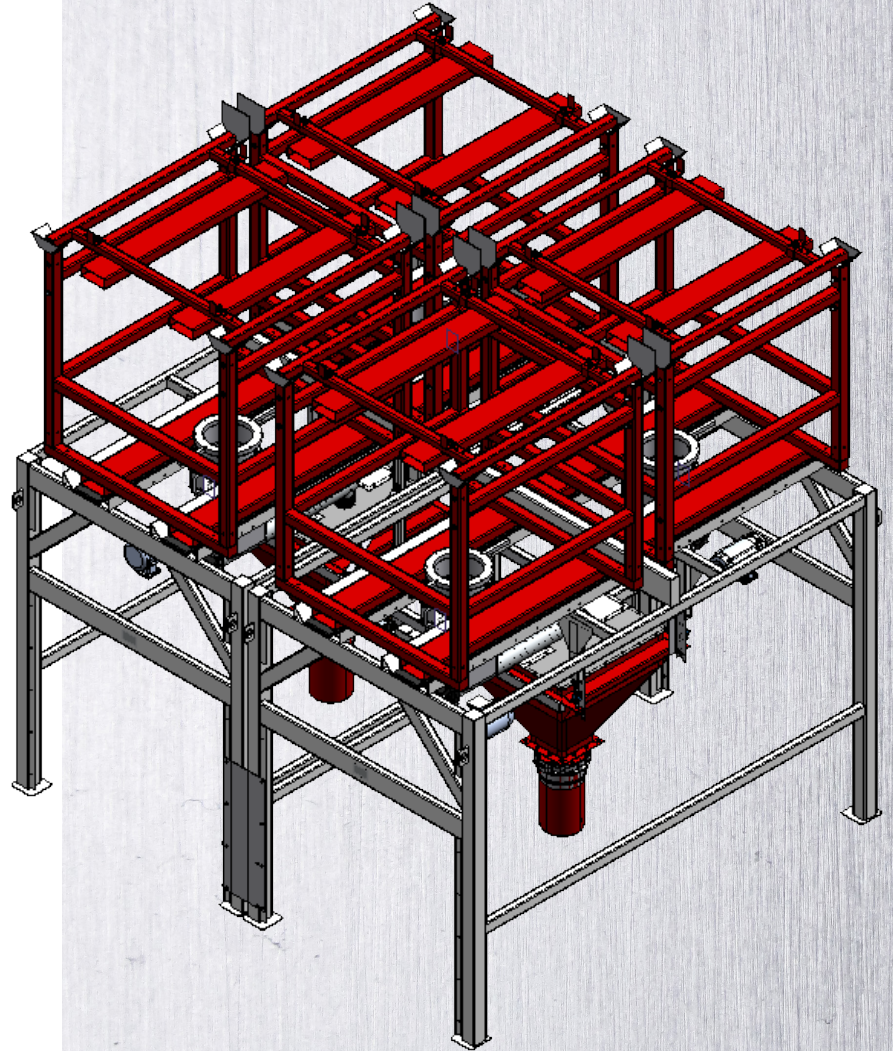
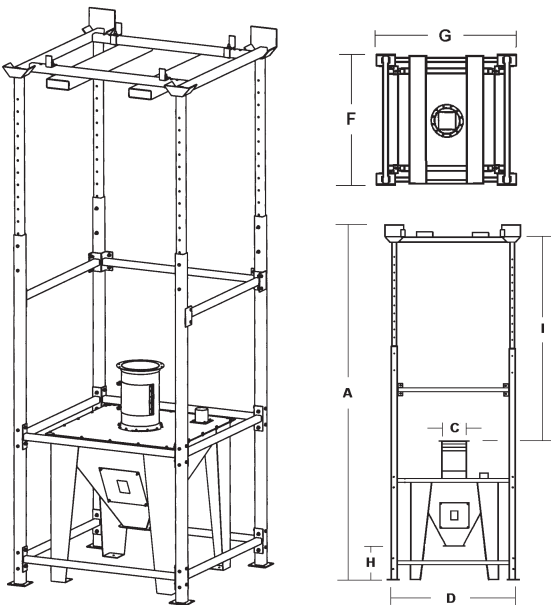

Sudenga
INDUSTRIES, INC.

1-888-SUDENGA | 1-712-475-3301 | Fax: 1-712-475-3320
PO Box 8, 2002 Kingbird Ave., George, IA 51237 USA
sales@sudenga.com | www.sudenga.com