

NEED FOR SEED.

PUT THE OX UNDERCAR BELT HOPPER TO WORK.



The Ox Undercar Belt Hopper is designed to move seed from low clearance hopper bottom trailers, trucks or wagons.



The Ox Undercar Belt Hopper's transport winches up, allowing the hopper to be swung easily. And the discharge even has an oversized handle to make moving the hopper an easy task. You'll be tempted to march it in the big parade, but you should probably just let it get to work. No fuss.

UNDERCAR BELT HOPPER



TRANSPORT JACK

STANDARD FEATURES

- 12" x 15' conveyor with 14" belting
- Capacities to 4000 BPH (5000 CFH).
- Transport winches up, allowing the hopper to be swung around easily.
- Transport raises the discharge point an additional 7" from a "level hopper" position.
- Discharge has an oversized handle to make moving the hopper easy.
- A remote lever collapses the hopper shroud for extra clearance and raises to minimize spillage.
- Spout is designed for gentle transition from incline to discharge.

SPECIFICATIONS

Tube	12 ga. mild steel tube - 12" diameter.
Belting	14" PVC belt with crescent top surface. 4" vulcanized drive roller; 4" self cleaning bottom roller; top and bottom bearings for belt tension and tracking.
Drive	Electric Drive - 400 FPM belt speed (variable by changing motor pulley). 5 HP is recommended (motor not included). Adverse conditions may require 7½ HP. Hydraulic Drive - includes 6.2 CID "H" Series motor.
Spout	Opening is 10" wide and 9" deep.

REACH & ELEVATION

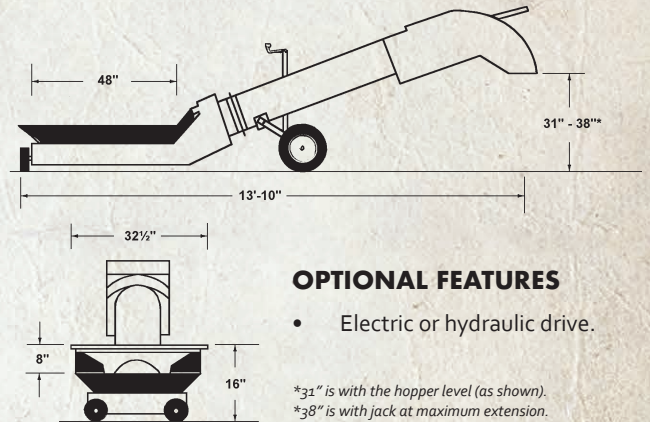

OPTIONAL FEATURES

- Electric or hydraulic drive.

*31" is with the hopper level (as shown).
*38" is with jack at maximum extension.



HOPPER SHROUD



THERE'S WORK TO DO.

Sudenga Industries • Box 8 • 2002 Kingbird Ave. • George, IA 51237 USA
1-888-SUDENGA (783-3642) • Fax: 1-712-475-3320 • sales@sudenga.com • www.sudenga.com